

which cylinder rings were always floating. Again, there was a marked difference between a cold engine and one under steam, and these points must all be taken into account. Then again, many of the builders of large engines in which the cylinders were tandem designed the cylinder feet so that the cylinders were free to slide in and out between machined surfaces, and in the face of all these facts he would be an exacting man who would demand gauging to a "feel"; let anyone take a micrometer gauge and set a pair of outside callipers to a size, then move the gauge even a small fraction of, say, $\frac{4}{1000}$ of an inch (which answers to a No. 4 feeler) and it would at once be detected. It was quite possible in gauging a wire to measure as close as this, and, in fact, a No. 6 or 8 feeler appeared to be a large amount. In a well-machined and set up job, alignment to a No. 4 feeler was quite easily obtained, and when one dealt with wires 30 or 40 feet long, such accuracy was practically perfect. The method of trying if glands were free when rods were in place was all right as a second resource, and certainly an engineer would use it, but it should always come after gauging the wires. Allowances in levelling also had to be made. For instance, theoretically the wire which passed through the cylinders and guides should also show true with the crank shaft centre, but if it did not, and could not be adjusted, then a slight error at this point was not of vital importance to the future running of the job, for the connecting rod would allow for any small difference. All other points, however, should be dead level.

The modern quick revolution engine had in many instances superseded the long stroke, slower running job, and it did not call for the same treatment in erection. It was short, vertical, and each part dovetailed into its receptive fellow; it was therefore, as a rule, only necessary to level up the component parts such as bed, crank-case,

trunks and cylinders; but, in addition, if it was to be coupled to a line of shaft or electric generator, then just as much care must be taken. In this case the couplings were principally depended on, and it was therefore advisable always to have couplings tried in the lathe and faced up. They should then never afterwards be taken off, as re-keying was liable to throw them out. In coupling together high speed shafts flexible couplings should be used wherever possible, as one shaft might be directly coupled to a machine where a different amount of wear might occur in the several bearings and a stress thereby thrown on the shaft which did not as a rule wear so much.

A word or two might not be out of place with regard to the alignment of gas engines. There were not many units in Australia where cylinders were tandem, and these, the author thought, would be erected on somewhat the same lines as he had indicated earlier in the paper, but the general type had the stout, short, heavy beds with trunk pistons and heavy fly-wheels on overhung cranks, and the spirit level was the most important gauge used in their alignment. As a rule the power was taken off the engine by belting, and consequently to bring the driver and driven pulleys into alignment became the centre of greatest interest. When an outer bearing came into the design it would call for proper care, and the general way was to treat the crankshaft as the guiding factor and to bring the bearing into its place and to then harden it up. The whole of the parts were usually so heavy and solid that the springing of a casting was out of the question, and so, generally speaking, the matter of alignment of these engines did not warrant such detail as was needed for steam engines.

So far he had dealt with horizontal lines and machinery on horizontal planes, and no doubt comparatively speaking there were more jobs of this kind than in vertical

planes (he was, of course, not speaking of vertical engines now), but nevertheless there were many arrangements where vertical lines only were employed. As an example of this class of work the author had prepared Fig. 5, which

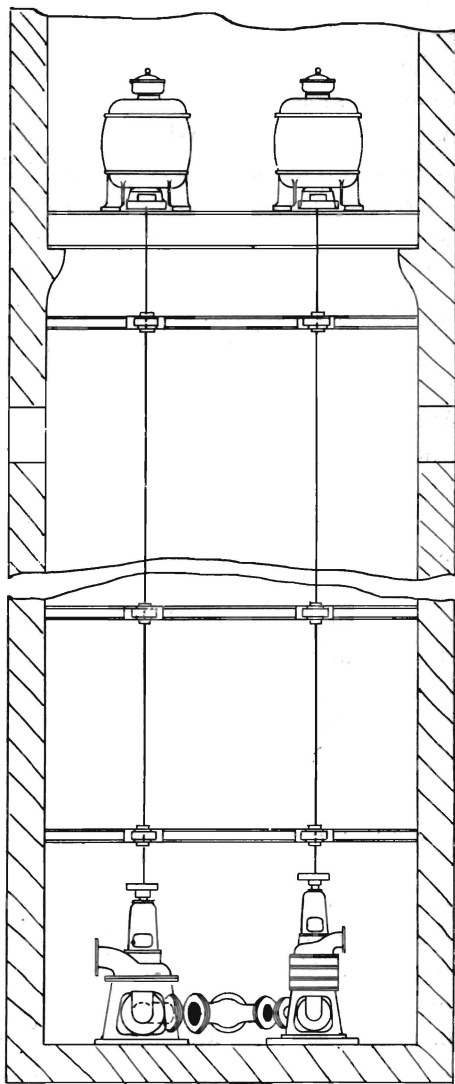

Fig. 5.

illustrated an arrangement of two centrifugal pumps placed in a well so that the motors were above flood level and the pumps had little or no suction head. This meant that in some instances the wells were deep, demanding long lengths of vertical shafting coupled together. In aligning this description of machinery the work was best carried out by means of very heavy plumb bobs and piano wires, and when the bottom plumb centre was found the wire was made fast to a support and tightly stretched. This was best done by drilling a fine hole in a rigid bar on the centre found by the plumb bob and then reeving the wire through this hole. It was a difficult matter to get a bob to remain steady at the end of a long length of line, but by using a bucket of water or even oil the bob came to rest much quicker and the oscillations were much less, particularly as the piano wires had no fibre to twist and untwist. When the wire was rigidly fixed at the top and bottom, the bearings should be fitted up and the brasses gauged from the lining wire, and as the shafting seldom exceeded 3in. in diameter, a steel rule with fine markings would be found a suitable guage. When the bearings were rigidly bolted to the cross bearers the shafting should be placed in them and the couplings bolted together. On no account should the bearings be adjusted to the shafts. It is of primary importance that the truth of the shafting and couplings should be tried in a lathe, for although in low revolution shafting a slight error might be passed over, when the number of revolutions amounted to 1000 and over no risks could be taken, as the slightest divergence from the truth in the couplings set up a marked vibration in the lines of shafting and caused heated bearings and other troubles.

It sometimes happened that in soft ground the pump well became distorted. It was then imperative to test the shaft, and if it was not practicable to remove it and run

the wire through the bearings, then two wires were necessary, making a triangle of the gauging points as shown in Fig. 6, the shaft forming the apex and the two wires

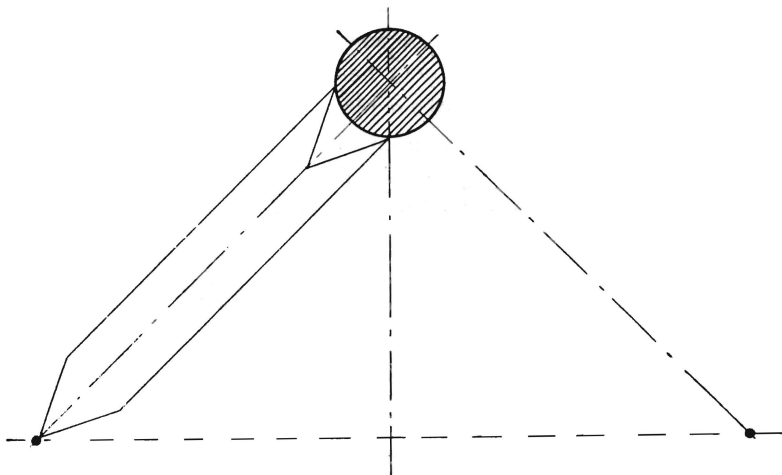

Fig. 6.

the extremities of the base line. A flat iron gauge was then used, with the butt end having a V in it and the other end being pointed. The alignment was tested by this means of all the bearing points, and if necessary in between such. By writing down the divergence from the truth on a drawing the whole of re-aligning became easier.

Vertical marine engines, the writer considered, were a class which called for different treatment to that accorded land engines. To his way of thinking they had more engineering skill expended on them than any other class, for in them there could be no running of wires in order to prove alignment. When first they were erected in the shop the important point of the alignment of each

guide with its particular cylinder was of first importance, and with this and a crankshaft absolutely true everything else was built up and fitted together. Every part of these concentrated and powerful machines was a separate study—how much should be allowed in a H.P. guide, how much in an L.P., how close a fit must the crank brasses be for end play and running, and so on. There was no doubt that the men who lined up marine engines first of all in the shop, and in after years when the engines were in place on board ship, used more or less individuality in doing so, and as they all knew, the engines responded in such a way that each vessel's engines became known, sometimes for generations of engineers, as "good jobs" or "bad jobs" and their weaknesses were discussed in mess-rooms and ashore just as if they were human, and many an epithet was launched at the head of some engineer in a far away shop on the Clyde or Tyne about something he had or had not done, "Where first in store the new made beasties stood," as their old friend McAndrew sang.

The lining of the machinery that was installed in vessels deserved a whole paper to itself, as the subject was such a special one, and, like everything else pertaining to ships, was the result of accumulated experience and in many instances of trial and error. Each part of the world had its own peculiar shipping, and here in New South Wales, up to the present, the work done consisted mostly of coasting craft built of hardwood, and ferry steamers of both steel and wood. The method adopted in these wooden steamers was to commence with a given height above the keelson and adjust or "humour" the line so as to make the best possible use of the deadwoods, and at the same time to get the necessary rake in the line of shafting. This gave the bedplate position, and the columns and cylinders follow in their turn. Where twin screws were used there was the additional bearing in the outer brae-

kets to consider, but as a rule it was the practice to fit these after the other parts were adjusted and to use the tail shaft as the guiding factor. As most of these vessels had the machinery arranged aft, there was only a short length of propeller shafting to be fitted up in a very rigid part of the vessel and where very little distortion occurred.

Most of our ferry steamers, however, were designed with a screw at either end, the shafting running the full length of the vessel, and as some of the shafts were in the neighbourhood of 150 feet long a great deal of care had to be expended in the lining off.

It was found that all wooden vessels of the ferry boat type "hog" after launching—that is to say, that when afloat the ends drop a certain amount—so that if the line of shafting were laid absolutely fair, when the vessel was launched it would be under a stress tending to bend it; but if, knowing this, the lines were depressed a certain amount at the engine bedplate position, they would take up the direction shown in Fig. 7.

By using this line as a centre the deadwoods were bored out and stern tube fitted; the tail shafts were then put in position, and working upon the couplings of these as guides, the line shafting was coupled up, the various bearings fitted to come in, and when bolted up all hard face to face the case with which the whole line was rotated was proof of the lining off. Every vessel, of course, had its own amount of "hog," but generally speaking the line is depressed $2\frac{1}{2}$ in. or thereabouts, and as the natural depression might be anything from $\frac{1}{2}$ in. upwards it would be seen to what extent experience was in the guide of the man responsible for the correct alignment.

Another procedure adopted, which was generally done with steel steamers, was by the sighting method. This operation was done by means of peep holes of small

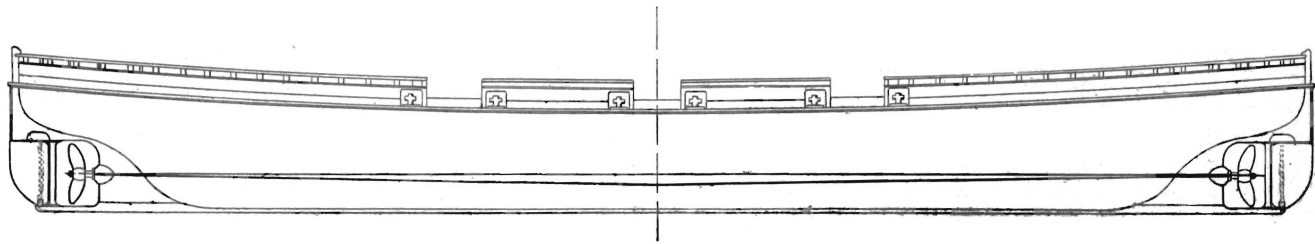

Fig. 7.

diameter. These holes were drilled in blank pieces of plate placed at the ends of the vessel and at the different bulkheads, with allowance for adjustment. By working at night and shining a bright light at one end, and sighting from the opposite end, these holes could all be brought into line. Then, using the peep holes as a centre, circles were described on the bulkheads and stern frames and the centres would then be picked up at any future time when placing the boring bars and bearings in position, for in future adjustments to allow for wear. In marine work there was so much vibration and so many stresses that shafting bearings had no close fitted caps, and so a certain amount of play was allowed for, but unfortunately no one could allow for all that might occur, and it was often found that the vessel, being in different trim, threw more weight on to one bearing than another, and very often additional adjustments were rendered necessary, so that the lining off could only be regarded as a starting point; the actual running tests were the final proof.

As the author stated at the outset, the subject he was dealing with was one of great scope, and he had really only dealt with it so far as it concerned shafting, and which might be considered the starting or basic point of erecting machinery. The multitude of arrangements that were possible with pulleys, belts (open, quarter twist, angle drives, and so on) demanded a full treatment and expert handling. The business of aligning toothed gearing and chain gear was also one that demanded the most careful treatment, and he trusted that members would touch on some of the many points that cropped up in these important subjects and which had not been referred to in detail in this paper. They were all more or less specialists nowadays, and it was not possible for any one of them to keep abreast of every branch of engineering even in such an elementary although extremely important subject as the alignment of machinery.