

much unnecessary machining and waste of material, so that forging from billets has almost become the universal practice.

On the other hand, high explosive shells being so much thicker in the walls, forging is not really an economical form of manufacture, but, nevertheless, forging has been carried out in this class of shell to some extent.

It may be of interest to illustrate the radius of action of shrapnel as compared with high explosive shells. What is commonly known as the beaten zone, viz., that area of ground actually covered by bullets in the case of the shrapnel shell, and the fragments of the shell body in the case of the high explosive, varies very considerably, but although the beaten zone of the high explosive shell is less than that of shrapnel, the effect of the high explosive is tremendous, and the impact set up in the air is mainly the cause of its effectiveness. It has been stated that the very sudden static depression of the surrounding atmosphere due to the force of some of the high explosive shells, frequently causes a stoppage of the circulation of the blood to those in the immediate vicinity. No other reason can be found to account for the fact that men have been found dead without the slightest sign of injury of any kind, whilst displacement of the heart and such other evidence points to the fact that it is the result of the pressure caused by high explosives, and not asphyxiation by gases. As a means of destroying fortifications, trenches, guns, etc., it is obvious that the H.E. shell is the only effective kind.

This method of manufacture certainly ensures a more sound base than if machined out of the solid. With a high explosive shell it is absolutely essential that there should be no piping or weakness of even a microscopic dimension at the base of the shell, for, if by any mischance the flame from the explosion of the propulsive

charge should reach the high explosive in the shell itself, disastrous results to the gun and those serving it would almost inevitably result. For this reason a base plate, with the grain of the metal running across the base of the shell, is inserted.

There is a sample of a high explosive shell on the table, but this is merely the result of experimental work, and cannot be taken as an example according to Government specification.

For the larger size of shell, as, for instance, the 4.5 howitzer, it is usual to pour the ingots to the size required, and by using a revolving table for the ingot moulds, a method adopted by a Canadian firm, ingots for 4000 shells are cast in 24 hours in cast iron moulds, having a life of over 200 heats. This method we are not likely to be associated with, so will pass over quickly.

Reverting again to the 18lb. shrapnel shell, the next Fig., 7, illustrates two methods of cutting off the blanks by circular saws. With a saw 30in. in diameter, it is

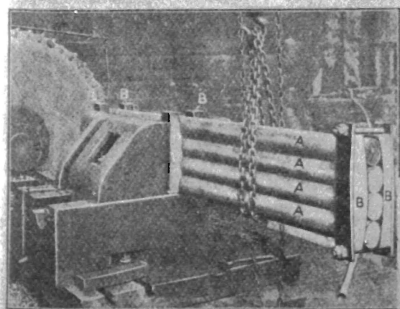

FIG. 3. CUTTING BLANKS ON A NEWTON COLD-SAW

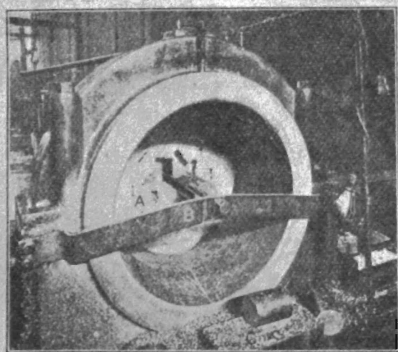

FIG. 4. GORDON COLD-SAW

Fig. 7

stated that 25 billets can be cut off every hour. For those who cannot, or do not wish to, use saws for the purpose, the next figure, No. 8, shows two other methods available, viz., group parting on planers, and parting off

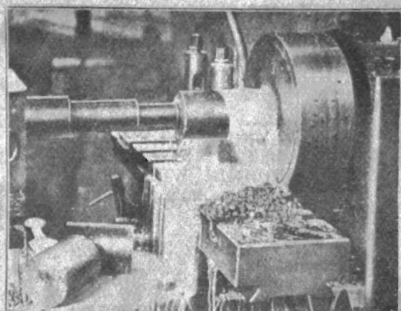

FIG. 5. CUTTING BLANKS ON TURRET

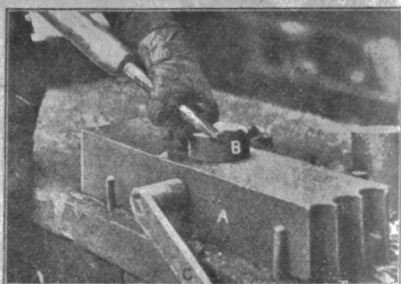

FIG. 7. REMOVING BURRS

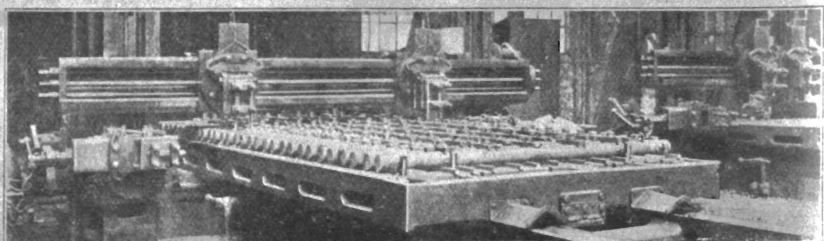

FIG. 6. CUTTING BLANKS ON THE PLANER

Fig. 8

the blanks in a high speed turret lathe. The planer method shown is capable of turning out 50 billets to cut off per hour, whilst by the high speed lathe 27 can be cut off per hour. Still another method is adopted, viz., the cutting off of the billets in a planer miller, with a group of saws carried on the arbor. The last-mentioned is the most expeditious of those shops equipped with such tools.

The temperatures during the forging of the shells are of the greatest importance. For the first operation, the temperature should be as near as possible 2000° F., and for the second operation 1800° F. Speeds also are of importance, and on the first operation, 30ft. per minute is satisfactory, and on the 2nd operation, 22ft. is all that the work can safely stand.

Fig. 9 illustrates by diagram a recognised standard method of piercing and drawing shrapnel forgings.

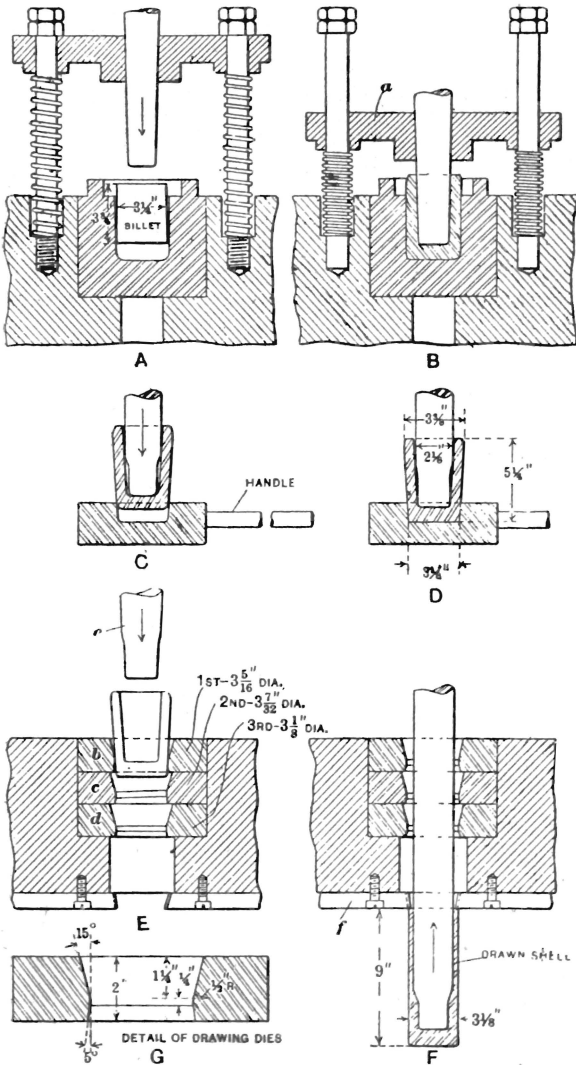

Diagram illustrating Method of Piercing and Drawing Shrapnel Forgings in a Power Press.

Fig. 9

Fig. 10 is of interest, for it describes what would undoubtedly be the most economical method of making the forgings if it was really practicable, that is, in one heat

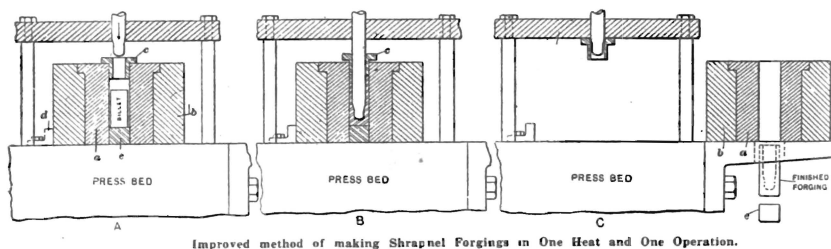

Fig. 10

and in one operation. It might interest members to know that at the C.S.R. Co.'s Pymont works, experiments have been made with a 500 ton press, to operate under this desirable method, but although successful in an experiment with iron, it has not been so with old railway axle steel, or the special material supplied by a local steel maker. It certainly seems, from later information available, that piercing and drawing of the forgings is the more universal method. On the table is shown a forging produced by piercing and forging at the Pymont Works. This has been made from Broken Hill steel, which, I understand, conforms to the specification of the Government for high explosive shells.

Although not necessary, hydraulic presses are often specially designed for the manufacture of shrapnel shell. it might interest members to know that the Angus Locomotive Shops, in Canada, turned out a 300 ton shell forging press weighing 30 tons, in twenty days, and in this time they designed it, made patterns, machined the parts, assembled them, and shipped the machine. Performances of this kind certainly indicate that the engineers of the

Dominion were not going to allow any obstacle to stand in the way of the successful manufacture of munitions.

It will not be possible within the scope of these notes to give the complete set of views of the methods of finishing shrapnel, and with which the lecture was illustrated, especially as the operations performed in finishing a shrapnel shell from the forged state to a finished body, packed in its case, are fairly extensive, and vary considerably according to the shop in which the work is done. For instance, in the works of the Ingersoll Rand Canadian Company, which I illustrated with a number of slides, the work is actually divided into 32 operations, but many of these are small, and so many shells being performed upon at one time, that the actual period spent on each shell body is not very great. These operations have been very amply described in the American technical journals—"The American Machinist" and "Machinery," and have been reproduced, and very ably demonstrated in the publication, "Munitions," issued by the voluntary Munitions' Committee in Victoria. In selecting certain of these operations for illustration herein, I have chosen those which, perhaps, are of exceptional interest, and because some of them are applicable to the operations in the manufacture of high explosive shells, which it is now understood are most likely to be required from Australia.

Fig. 11 illustrates a method adopted for the cutting of the waves and recess for the copper driving band, and this is the same for both shrapnel and high explosive shells. The wave rings, as you are doubtless aware, are for the purpose of preventing the driving band from revolving on the shell body, when the rifling in the barrel of the gun is transmitting the rotary motion to the shell.

The shrapnel shell requires special heat treatment, but the high explosive does not; this simplifies very much the manufacture of the latter.

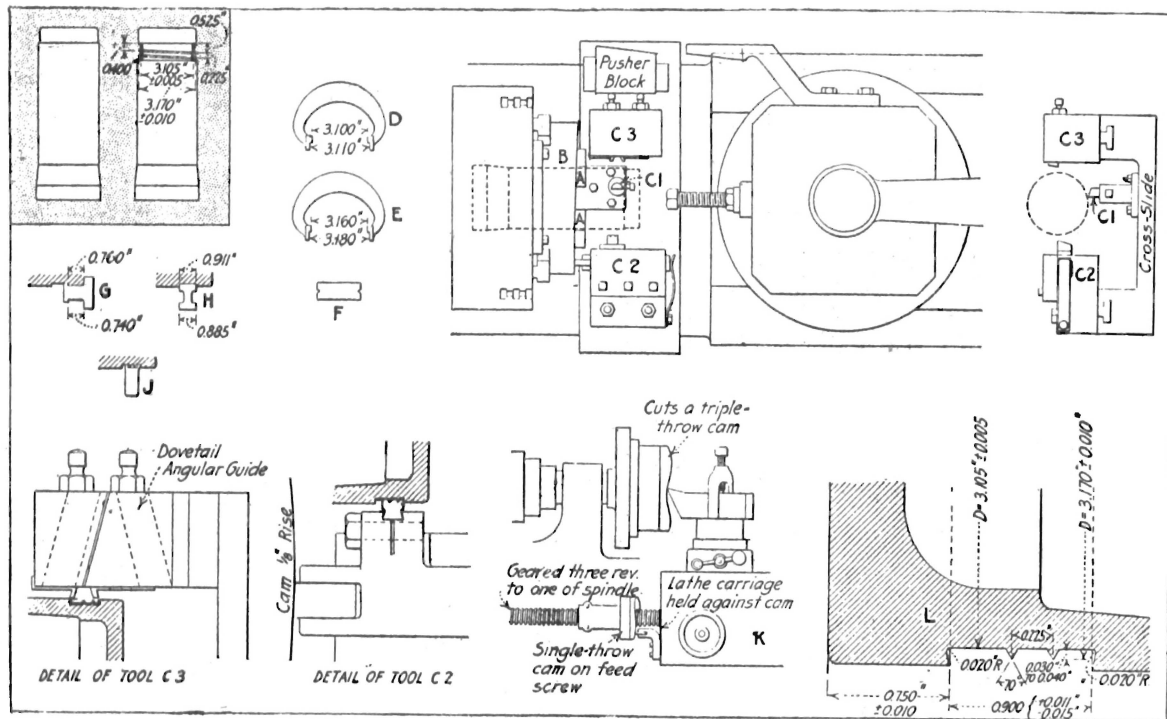

Fig. 11

Fig. 12 illustrates the press used by the Ingersoll Company for crimping on the copper driving bands. The action of this pneumatic tool is apparent. Several differ-

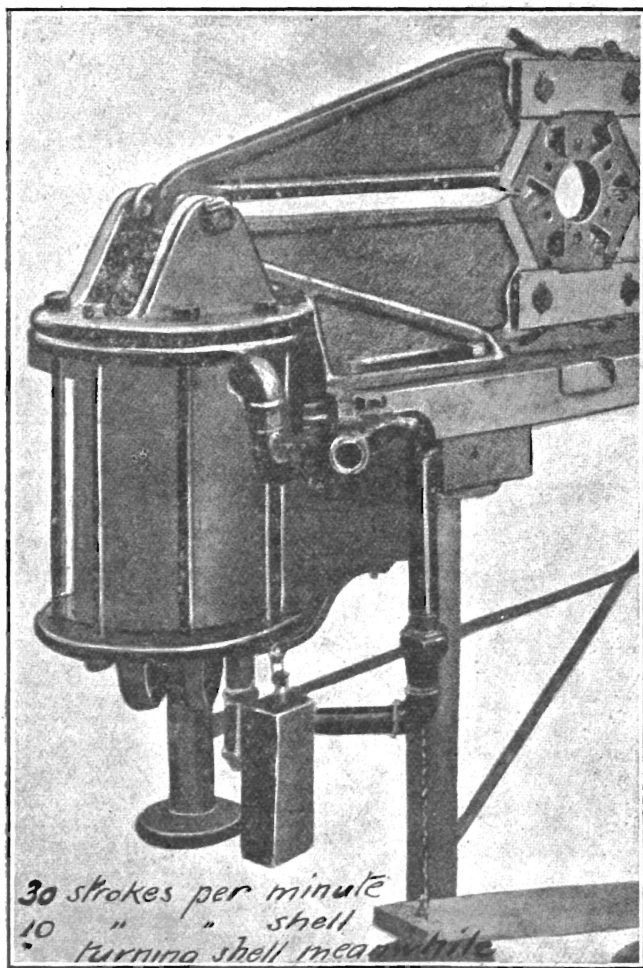
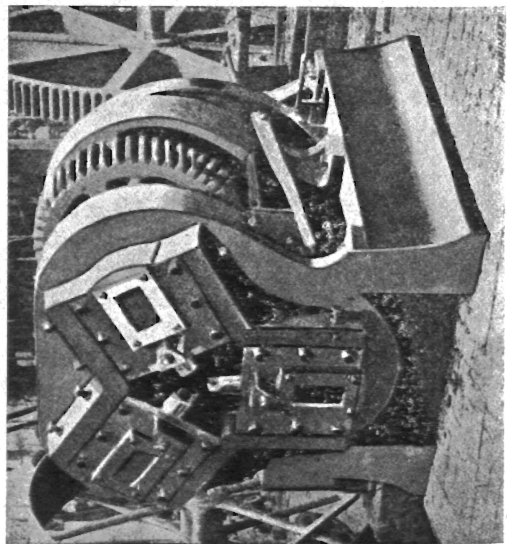
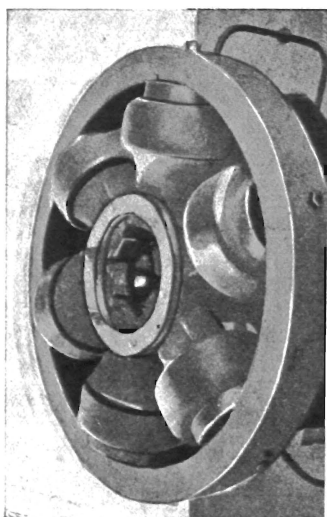
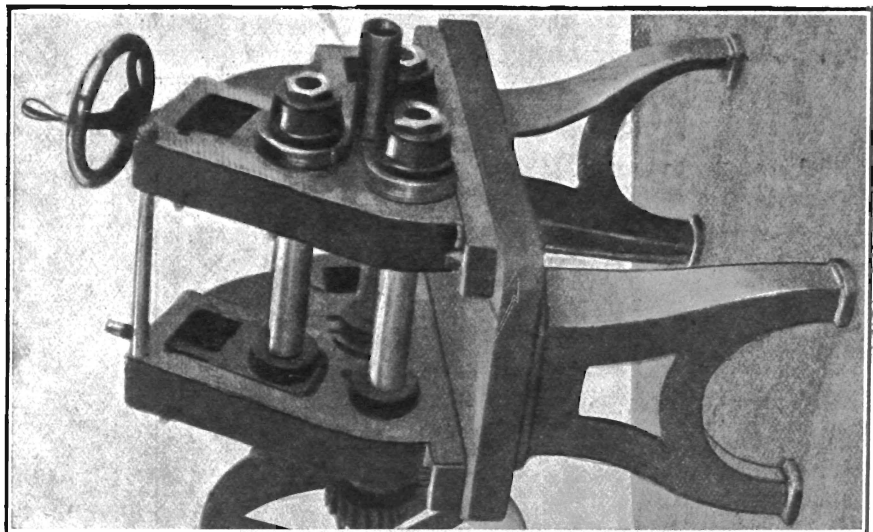
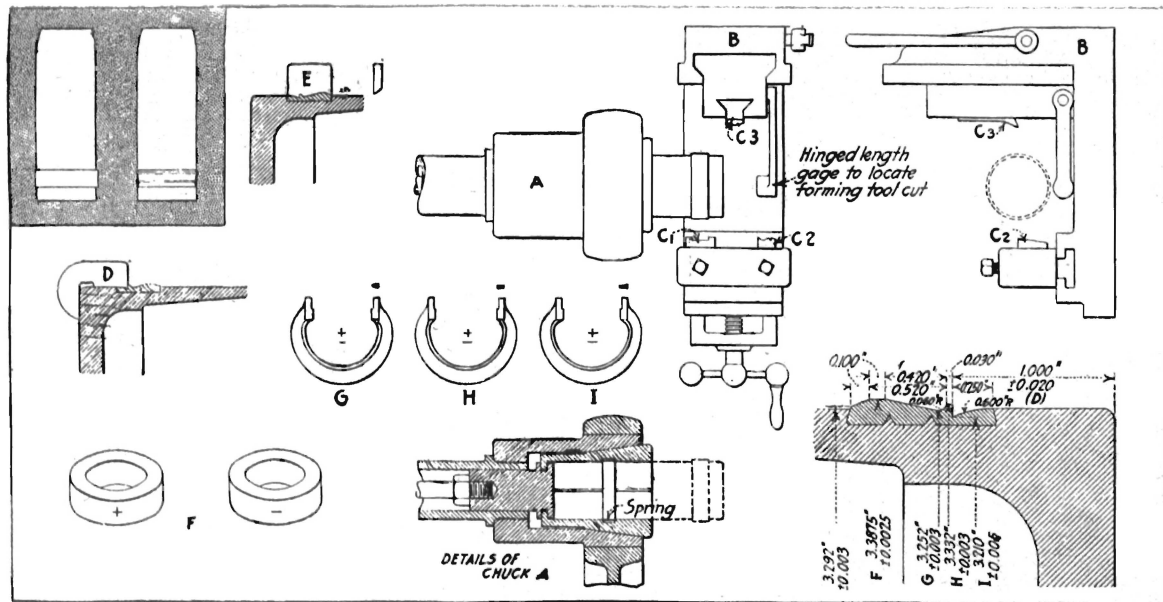

Fig. 12

ent types of machines are used for the purpose, and Fig. 13 indicates 3 machines of different kinds that have been designed for the purpose. The first is a horizontal hydraulic machine, the second a power driven machine,



and the third a rolling machine. The last-mentioned operates on a strip of copper and rolls this into position, whilst the other machines force a copper ring of the required section, and which can be passed over the shell



OPERATION 21 TURN AND FORM DRIVE BAND

Machines Used—Brass lathes and engine lathes with special forming slides.

Special Fixtures and Tools—Draw-in collet-chuck, A, and special forming slide, B. Cutting tools: Width tool, C1; rough turning tool, C2; finish forming tool, C3.

Gages—For height of radius from base, D; for form of band,

E, for \pm diameter at F, F, for \pm diameter at G, G; for \pm diameter at H, H; for \pm diameter at I, I.

Production—From one machine and one operator, 15 per hour.

Note—Previous to using the rear forming slide for finishing, the shell became so hot that it was necessary to fill it with soda water and plug the end before this operation.

Fig 14.

proper, into the driving band recess. The copper band is, of course, afterwards machined to the correct shape externally.

Fig. 14 gives some details of the driving band, and shows a method of chucking the shells for the operations of turning and forming the band. For filling the shrapnel shell with resin, an ordinary electric pot is frequently used for melting the resin. With regard to filling shrapnel shell with balls, or bullets, ordinary accurate lever scales are used for weighing. Both of these operations must be carefully performed, as the limit of tolerance allowed for the resin is $4\frac{1}{2}$ dr., more or less, and the limit for the balls is one ball, more or less. The weight of the shrapnel shell when filled with balls, being 16lbs. $15\frac{1}{4}$ ozs. and when filled with resin, 17lbs. 10ozs. $14\frac{1}{2}$ drs.

During the manufacture of shrapnel shell there is, of course, a series of gauging operations, and whereas the total number of inspections or gaugings on an ordinary shrapnel shell amounts to 40, none of these are of an exceptionally rigid nature, or outside the scope of an ordinary well run engineering shop. There can, of course, be no room for laxity, but the limits of tolerance are reasonably liberal. The H.E. shells require only 22 gauges, and these are of a similar kind to those of the shrapnel.

A typical illustration of the gauges required for shop and Government inspection are shewn in Fig. 15. It may be of interest to mention that six Government Inspectors can take care of both the first and the final inspection of 600 shrapnel shells per day. The first inspection is made before the nose of the shell is closed in, and particular attention is paid to defects and flaws, especially at the base of the shell, so that further labour will not be put on defective cases. At this stage, the carbon content of each lot of shells is stamped on the shell base. From each batch or cast of, say, 120 shells, one is selected, and from this, tensile strength pieces are cut for testing. Reference should be made to the fact that in many cases, external turning of the shell bodies is displaced by grinding. Special wide wheels are used for grinding the

parallel portions of the shell, and curved wheels for grinding the nose portion. With good tools, this method may be more economical than turning, but a high finish is not required.

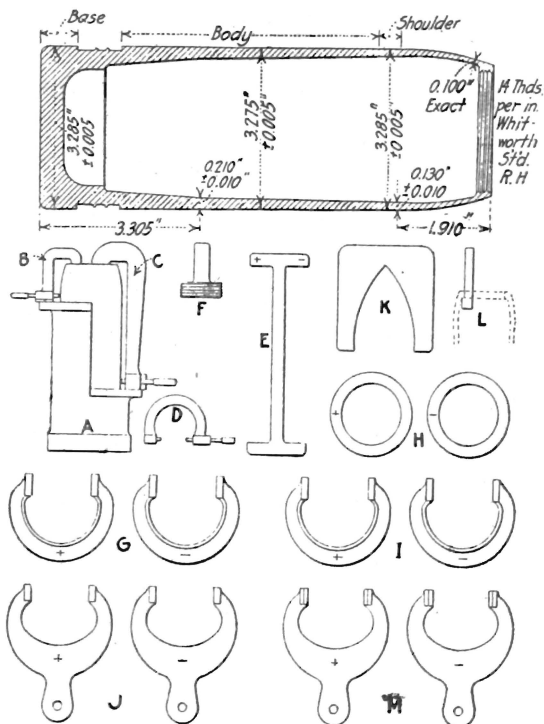

OPERATION 18 SHOP INSPECTION

Special Fixture—Holder for shell for gaging wall thickness, A

Gages—Micrometer for wall thickness, B; for wall thickness, C; for wall thickness, D; for ± overall length, E; for thread in nose, F; for ± diameter of base, G; for ± diameter at shoulder, H; for ± diameter over waves, I; for ± diameter over waves, J; for nose profile, K; for depth of nose recess, L; for ± diameter of bottom of wave recess, M. Total of 17 gaging operations.

Production—Sixty shells per hour for two men.

Fig. 15.

For carrying out the hardness test, the Shore Scleroscope has been largely used, and Fig. 16 shows a diagram illustrating the relation of the hardness scale to the elastic

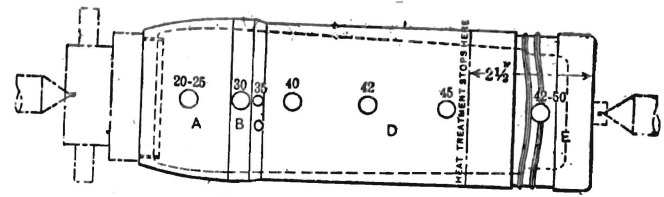
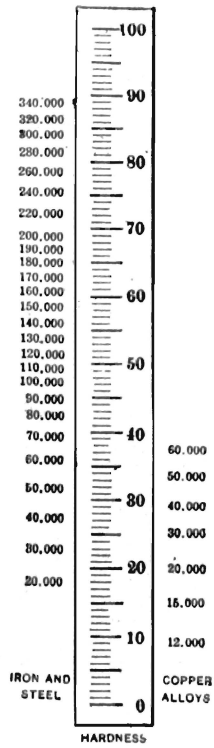
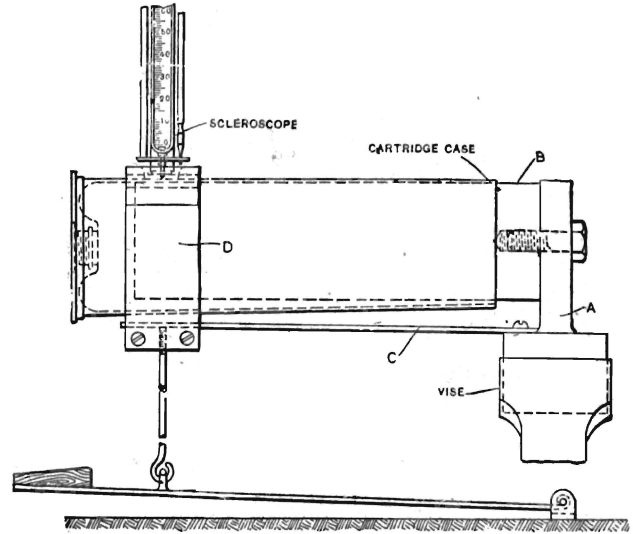
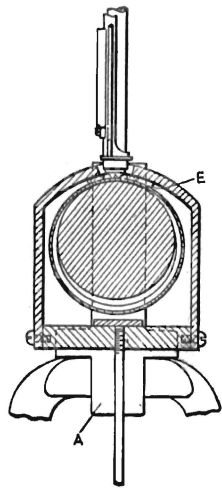

Diagram showing Scleroscope Hardness Test of Heat-treated Shrapnel Shell at Various Points along its Surface.



Relation of Hardness Scale to Elastic Limit of Iron, Steel and Copper Alloys.

Fixture for Testing Hardness of Cartridge Cases with Shore Scleroscope.

Fig. 16